



WaterHog™ COMPRESSED AIR CONDENSATE TRAP

ZERO LOSS



- **POWERS THROUGH CONDENSATE BUILD UP**

Ideal for Compressor Applications Up to 100 hp. The WaterHog™ Design Avoids Small Passages Ensuring Clog - Free Operation.

- **FULLY AUTOMATIC OPERATION**

No Timer or Manual Settings.

- **NO ELECTRICAL CONNECTIONS**

WaterHog™ is Powered by Compressed Air, Avoiding the Need for Electrical Wiring and Connections.

- **ENERGY SAVING OPERATION**

Zero Compressed Air Loss*. Check With Your Utility to See If the WaterHog™ Qualifies for Energy Efficiency Incentives. The WaterHog™ Pays for Itself When Replacing Open Condensate Drains Valves or Timer Traps.

- **LOW PROFILE**

The 4.7" Vertical Operating Height Allows the WaterHog™ to Fit Where Other Larger Units Can't.

- **2 Year Warranty**

LH50-OLAAA	
Maximum Operating Pressure	200 PSIG
Min/Max. Control Pressure	40/130 PSIG
Min/Max. Temperature	34°F/170°F
Inlet/Outlet Connections	1/2" npt
Weight	12 Lbs.

It is Recommended to Install a 5 Micron Air Filter on the Control Air Supply Line (MCWF03-18PB)

*When Properly Installed With the Balance Line

Effective 1-2015 Subject to Change Without Notice

How the WaterHog™ Operates Its Simple and Efficient

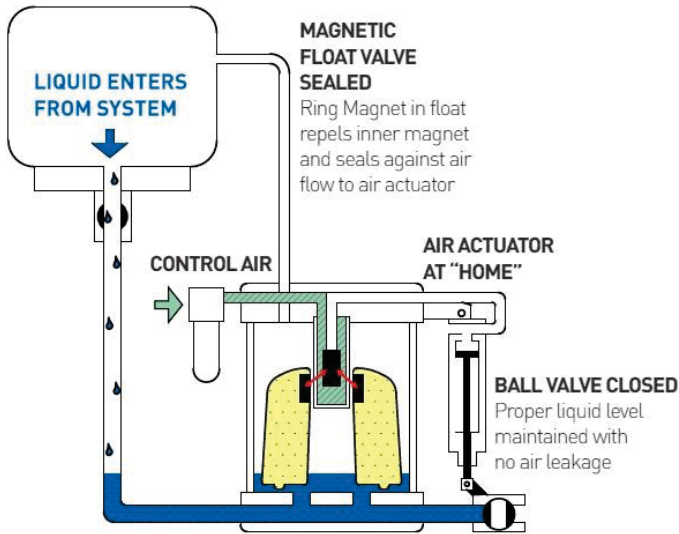

Figure 1 Start of Cycle

The Polymer Float With Integral Magnet is Resting on the Base of the Reservoir. The Integral Float Magnet Exerts a Magnetic Force Repelling the Inner Magnet Upward and Holding it Seated Against an Orifice in the Lower End of the Control Air Valve Stem. The Control Air Circuit, Including the Inner Magnet and Valve Stem, is Isolated From Liquid that Flows Into the Reservoir. The Air Actuator is in the Home Position and the Discharge Ball Valve is Closed.

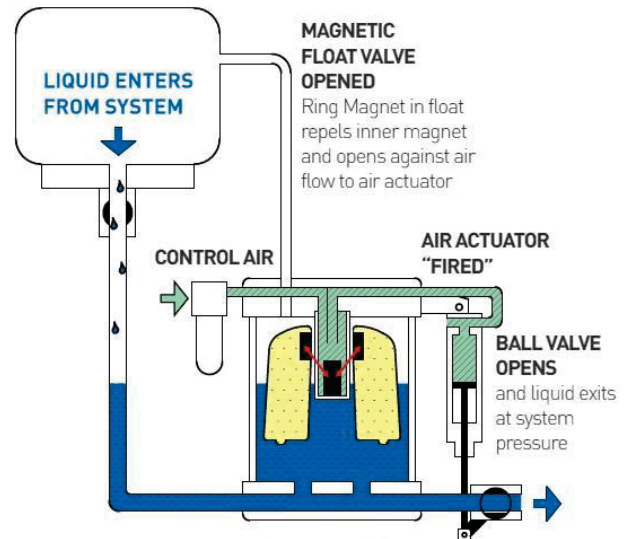

Figure 2 Start of Discharge

Liquid Continues to Flow Into the Reservoir and Raises the Float to its Highest Position. The Integral Float Magnet is Then Raised Up Past the Inner Magnet and Repels the Inner Magnet Downward Opening the Orifice in the Control Air Valve Stem. This Allows the Control Air From the Center Tube to Flow Through to the Other Side of the Control Air Circuit to the Actuator. Control Air Pressure Extends the Air Actuator and Opens the Ball Valve Starting the Discharge of the Liquid Accumulated in the Reservoir.

Frequently Asked Questions

Where Should a Water Hog™ be Installed?

At Liquid Accumulation Points Within a System at Compressors, Air Receiver Tanks, Intercoolers, Aftercoolers, Dryers, Separators, Filters and Drip Legs.

Is It Mandatory to Use a Balance Line?

Yes. The Balance Line Provides a Means to Handle the Displaced Air From the Reservoir as the Liquid Enters the Reservoir.

What Size Compressor Can It Handle?

The WaterHog™ Will Function Effectively on Any Size Compressor, Compressed Air System, Up to 100hp.

Can the WaterHog™ be Used to Drain Multiple Tanks and/or Compressor Systems?

No. They Will Not All be of Precisely the Same pressure Level and the Liquid Would Accumulate in the Lowest Pressure Drain or System Thereby Bypassing the WaterHog™. Also, the Use of Check Valves in Multiple Drains to One WaterHog™ Installation Will Not Make This Work Properly. Always Install One WaterHog™ for Each Item of Equipment to be Drained.

Can the Balance Line and the Control Air Line be Hooked Together Via a Tee Connection?

No. Do Not Do This. Each of These Air Lines Has Its Own Specific Purpose and Should Never be Tied Together. The Control Air Should be the Cleanest Driest Air Available Since it Supplies Air to the Control Circuit to Operate the Pneumatic Actuating Cylinder Which Functions Best and Lasts Longer if Clean Dry Air is Used. The Balance Line Allows the Air in the Reservoir to Move Out Leaving Room in the Reservoir for the Incoming Liquid. This Air Contains Moisture that Would be Drawn Across a Tee Fitting Tied to the Control Air Line and be Pulled Directly Into the Control Air Circuit, Which Can Damage Control Air Pathways and the Air Cylinder.





Installation Steps

1. Prior to Installing the Trap, Isolate, Depressurize and Blow Down the Vessel Being Drained to Remove Excessive Rust, Scale, and Dirt Knocked Loose During Piping Installation.
2. Remove the Trap From the Box and Set It In an Upright Position Where it Will Be Connected. To Ensure Proper Operation in All Installation Layouts, the Top of the Trap Should Be Lower Than the Bottom of the Vessel Being Drained.
3. Using 1/2" Pipe, Connect the Vessel Being Drained to the 1/2" Liquid Inlet on the Base of the Trap. Be Sure to Install a Shut-Off Valve and a Bypass Valve Between the Vessel Being Drained and the Trap. This Will Allow Easy Removal of the Trap "On the Run" During Any Preventive Maintenance Activities.
4. Using 1/2" Pipe, Connect the Trap Discharge Outlet to a Sealed Drain Pipeline or Enclosed/Covered Trough. The Discharged Liquid is Under Pressure and Can Splash Back if Directed Downward Toward the Bottom of a Simple, Shallow, Open Through-Type Floor Drain. **Please Ensure that the Ball Valve Does Not Rotate During the Discharge Pipe Installation.** The Linkage Between the Ball Valve and Air Cylinder Must Be Vertical to Prevent Binding.
5. Connect the Balance Line From the Trap to the Appropriate Connection Point on the Vessel Being Drained. The Balance Line is Used to Prevent a Vapor Lock in the Trap. **It is Very Important that the Balance Line Never Droops or Slopes Upward.**
6. Connect the Control Air Supply Line to the Control Air Inlet Port on the Trap. **It is Recommended to Install a MCWF08-18BP 5 Micron Air Filter on the Control Air Supply Line.** In Addition to the Filter, Always Use the Cleanest and Driest Air Possible to Ensure Long Term, Maintenance Free Operation.
7. Restart/Re-pressurize System and Check for Leaks at Pipe and Fitting Connections

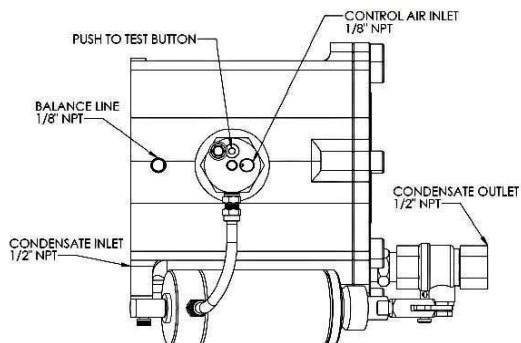

Specifications

Max. Liquid Temp	170°F
Max. Liquid Pressure	200 PSIG
Control Air Pressure	40 to 130 PSIG
Capacity	Varies With Pressure/Piping
Housing and Front Plate	Anodized Aluminum
Control Circuit and Air Cylinder	Aluminum
Float	Polyurethane
Housing Seal and O-Rings	Fluorocarbon
Fittings	Brass
Ball Valve	Nickel Plated Brass
Front Plate Hardware and Clevis	Zinc Plated Steel
Control Lever and Shouldered Bolt	Stainless Steel

Dimensions and Technical Data

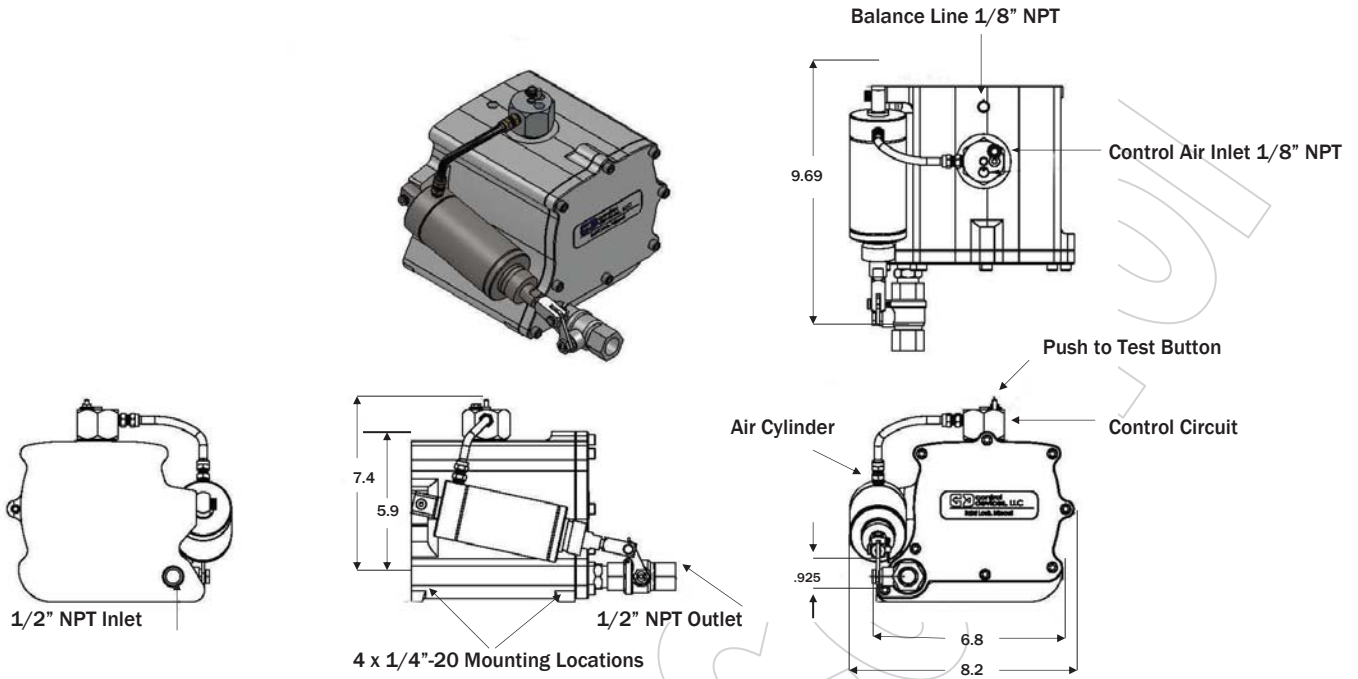

Installation Methods

METHOD 1

USE THIS PIPING LAYOUT DRAWING IN THE CASE WHERE THE BOTTOM OF THE VESSEL BEING DRAINED IS ABOVE THE TRIGGER POINT OF THE TRAP BUT NOT HIGH ENOUGH TO CONNECT THE BALANCE LINE TO THE VERTICAL SECTION OF THE DRAIN LINE.

CONNECT THE BALANCE LINE TO THE VESSEL BEING DRAINED SUCH THAT THE PRESSURE OF THE LIQUID ENTERING THE TRAP IS THE SAME AS THE PRESSURE ON THE BALANCE LINE.

THE BALANCE LINE MUST BE SLOPED FROM THE CONNECTION POINT ON THE VERTICAL DRAIN LINE DOWNWARD TOWARD THE TRAP.

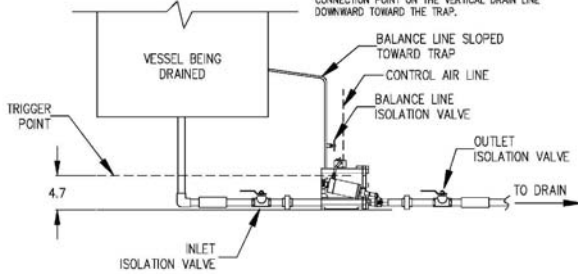

METHOD 2

USE THIS PIPING LAYOUT DRAWING IN THE CASE WHERE THE BOTTOM OF THE VESSEL BEING DRAINED IS ABOVE THE TOP OF THE TRAP ENOUGH THAT THE BALANCE LINE CAN BE CONNECTED TO THE VERTICAL SECTION OF THE DRAIN LINE AS SHOWN.

THE BALANCE LINE MUST BE SLOPED FROM THE CONNECTION POINT ON THE VERTICAL DRAIN LINE DOWNWARD TOWARD THE TRAP.

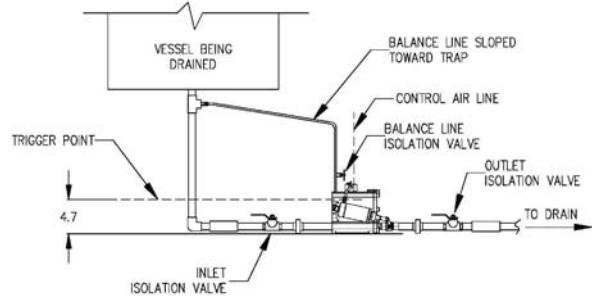

METHOD 3

USE THIS PIPING LAYOUT DRAWING IN THE CASE WHERE THE BOTTOM OF THE VESSEL BEING DRAINED IS BELOW THE TRIGGER POINT OF THE TRAP (4.7 INCHES ABOVE THE FLOOR).

IN THIS CASE, THE BALANCE LINE MUST BE VENTED TO ATMOSPHERE TO PREVENT LIQUID FROM ACCUMULATING INSIDE THE VESSEL BEING DRAINED. SEE THE PRODUCT INSTALLATION GUIDE FOR THE PROCEDURE ON ADJUSTING THE AMOUNT OF VENTING PROPERLY.

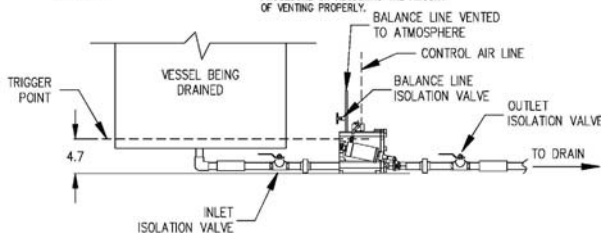

TYPICAL BYPASS CIRCUIT

